

# The Red Jacket® Submersible Turbine Pump Components

FIXED SPEED  
RELIABILITY

## Unitized Motor and Pump (UMP)

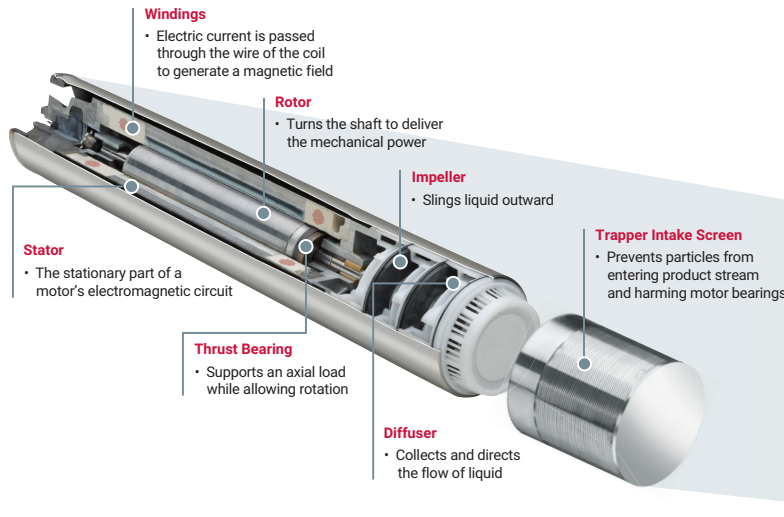

## The Red Jacket® STP

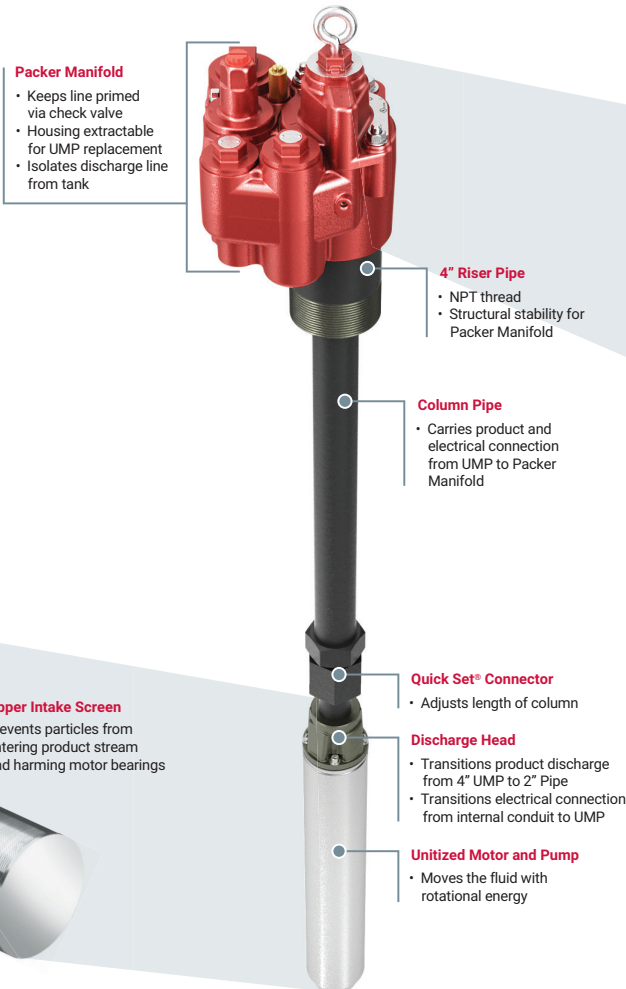

## Packer Manifold

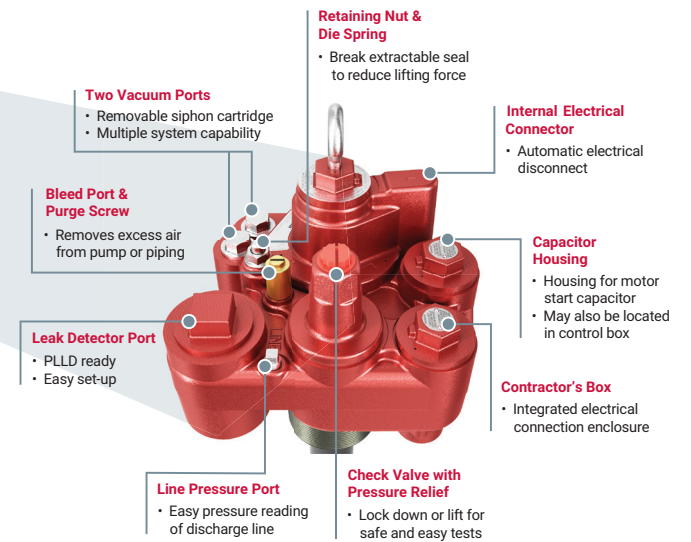

REDUCE SERVICING  
& AVOID DOWNTIME